

组装版300克便携舱

XMIND IEA300 Lite

拼装说明

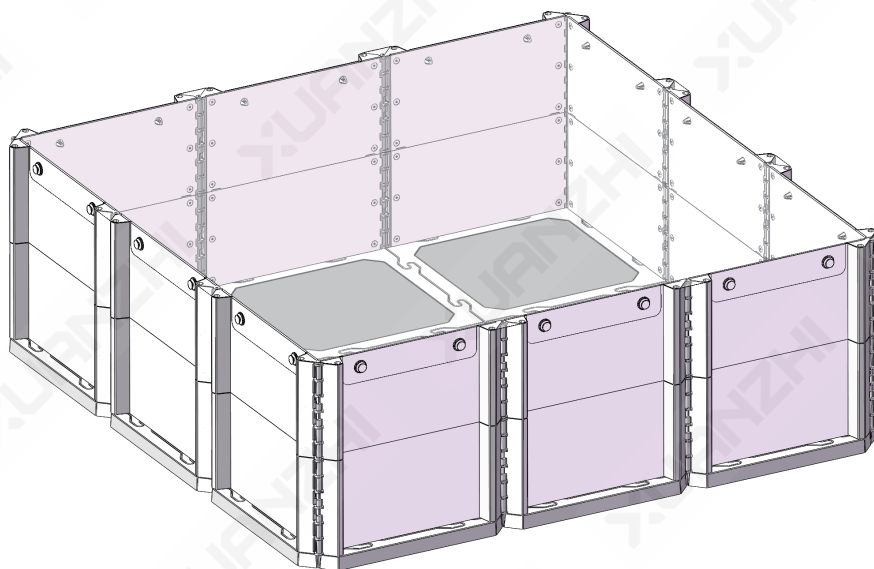

2023.8.29



安装前请仔细阅读以下提示

- 1.安装前请根据物品清单, 检查物料有无遗漏
- 2.所有安装步骤需均匀用力、缓慢压入, 切勿暴力安装
- 3.每次使用产品前请检查各个部位是否安装到位、保证舱内清洁, 以免在使用过程中发生危险

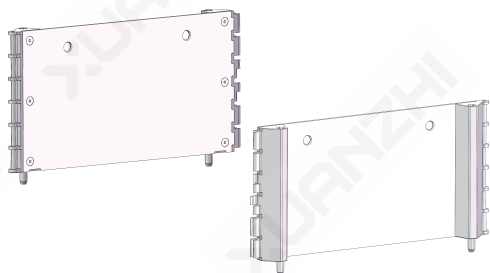
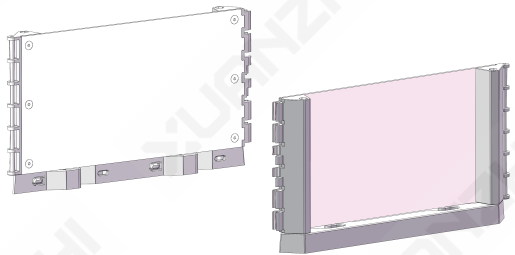
物品清单

<p>龙骨底板×9</p> 	<p>保护罩(带扣)</p> 
<p>上层围栏×12</p> 	<p>下层围栏×12</p> 
<p>一字螺丝刀×1</p> 	<p>保护罩便携束口袋×1</p> 

第一步:拼装底板

○拼装底板时请注意按平, 以免影响后续使用

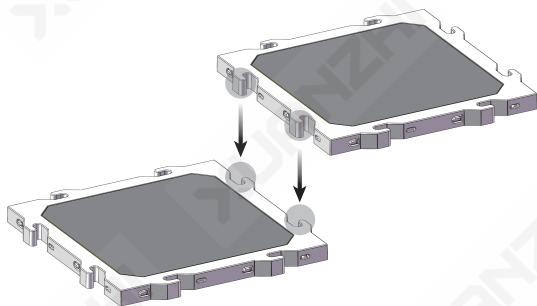

①将底板按照对应的卡扣位置进行扣合

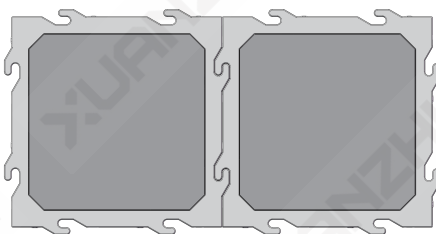

②底板之间扣合稳固



③将9块底板拼接成3×3的平面

第二步:拼装下层围栏

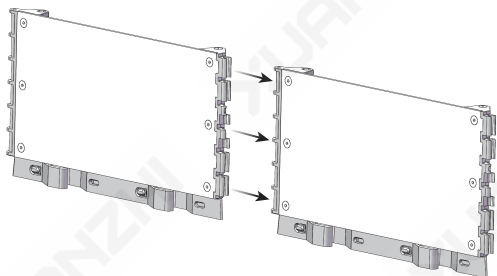

④ 将12块下层围栏拼在一起

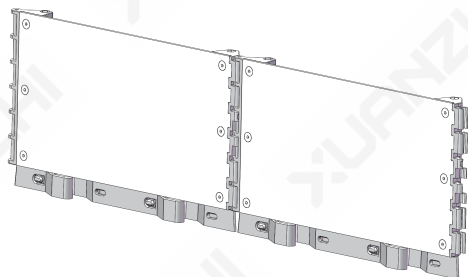

⑤ 拼合效果

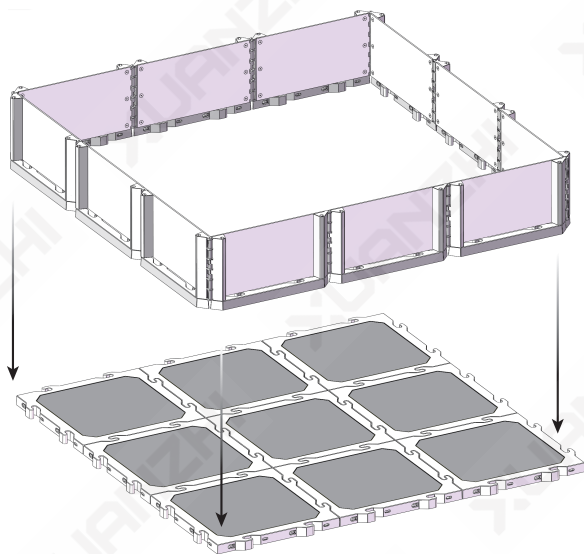

⑥ 将12片拼合好的围栏和底板进行组合

注意

- 请注意上层围栏与下层围栏的区别
- 拼合围栏时请注意安装到位, 以免影响后续使用
- 请将围栏全部拼好呈环形再插入底板, 否则第⑦步无法完成

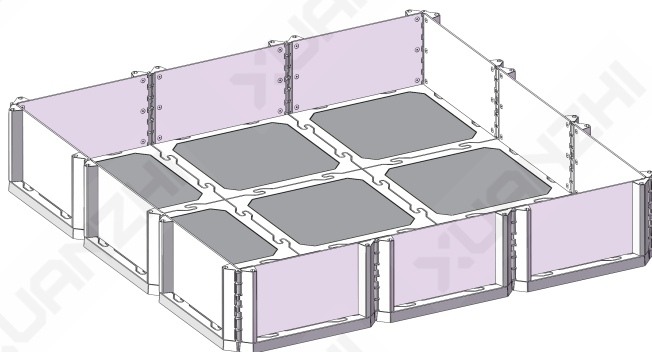

⑦ 拼合效果

第三步:拼装上层围栏

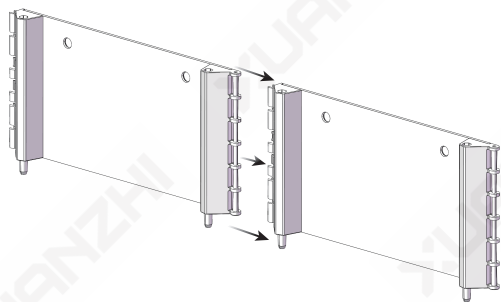

⑧ 将12块上层围栏拼在一起

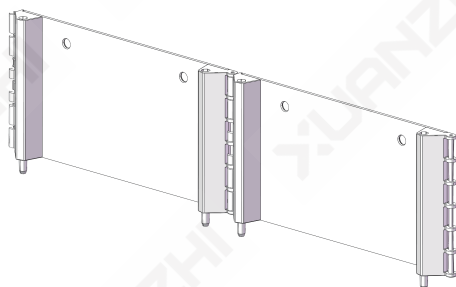

⑨ 拼合效果

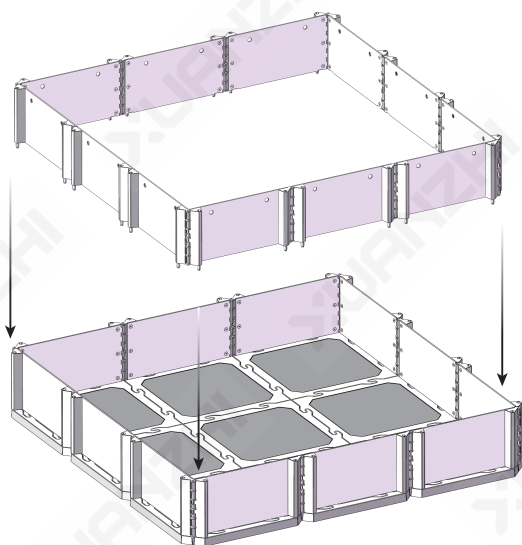

⑩ 将12块拼合好的围栏和第⑦步的组件进行组合

注意

- 请注意上层围栏与下层围栏的区别
- 拼合围栏时请注意安装到位, 以免影响后续使用
- 请将围栏全部拼好呈环形再插入底板, 否则第⑩步无法完成

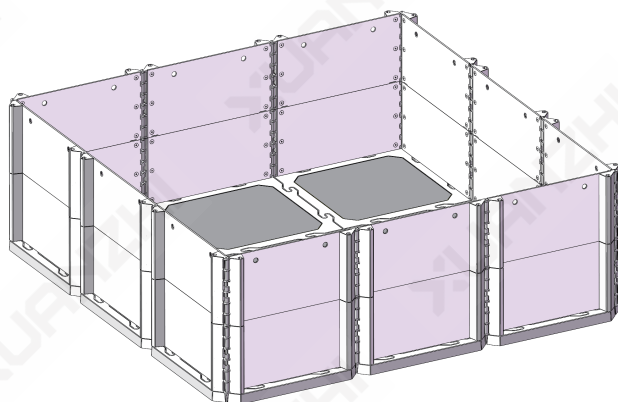

⑪ 拼合效果

第四步:拼装保护罩

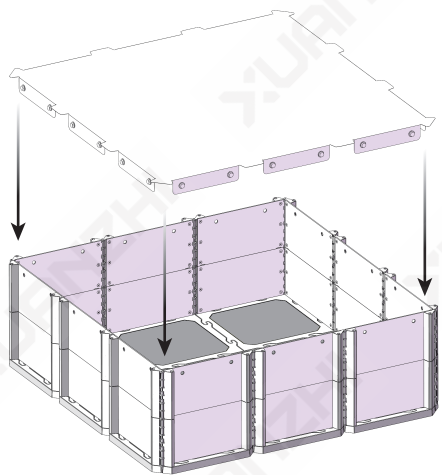

⑫ 将保护罩和第⑪步组件进行结合

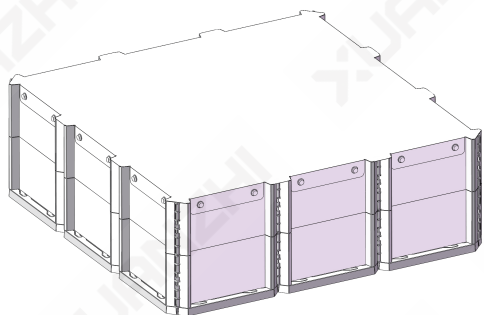

⑬ 拼合效果

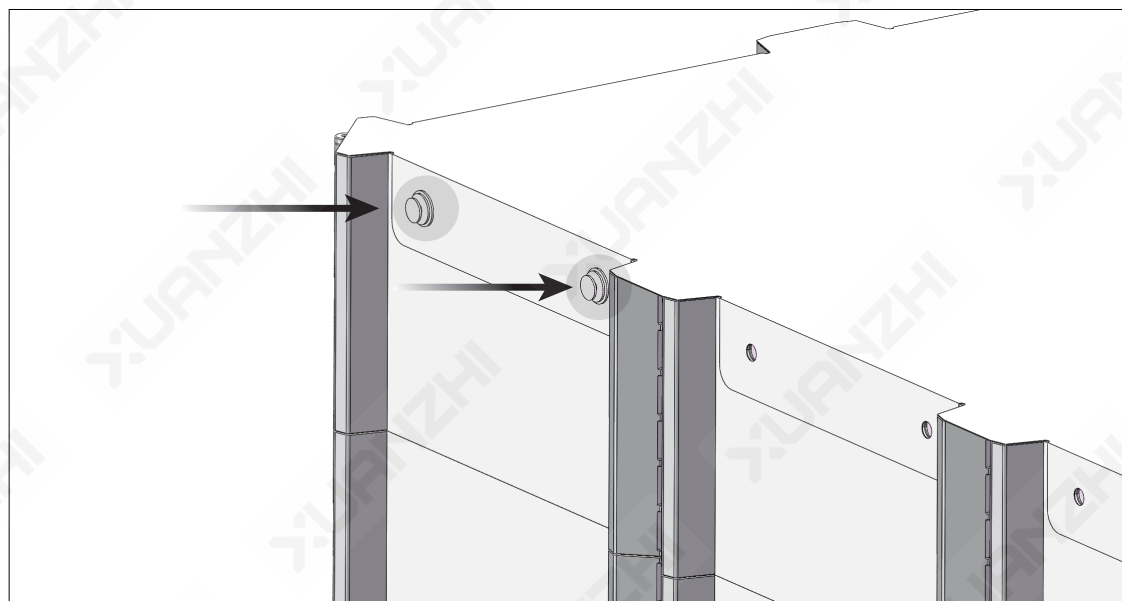

每次开始使用产品前,请确认保护罩连接扣与围栏扣紧,以免在使用过程中发生危险

- 由于在拼装特殊形状的条件下无法使用保护罩,使用过程中请勿使用解锁卡,以免发生危险
- 可以根据不同需求拼装成其他形状,例如:长方形、异形

示例

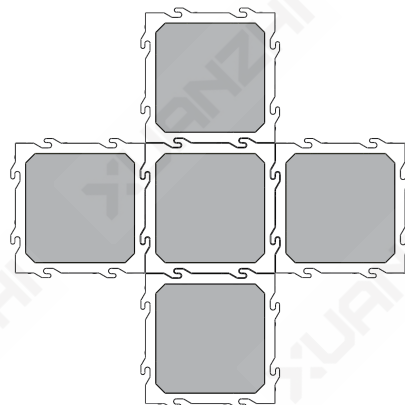
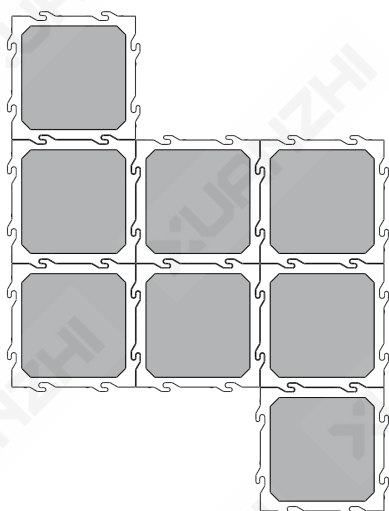
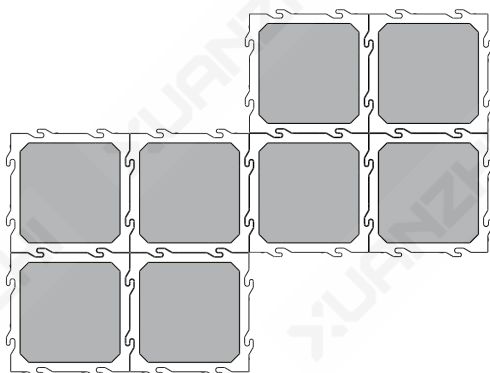
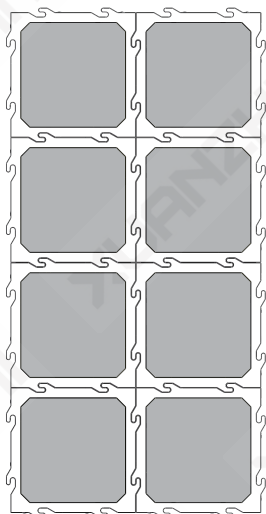

- 如果您需要将一层围栏与二层围栏分离,可使用一字螺丝刀
- 为了不对围栏造成损坏,建议您从角落开始进行分离

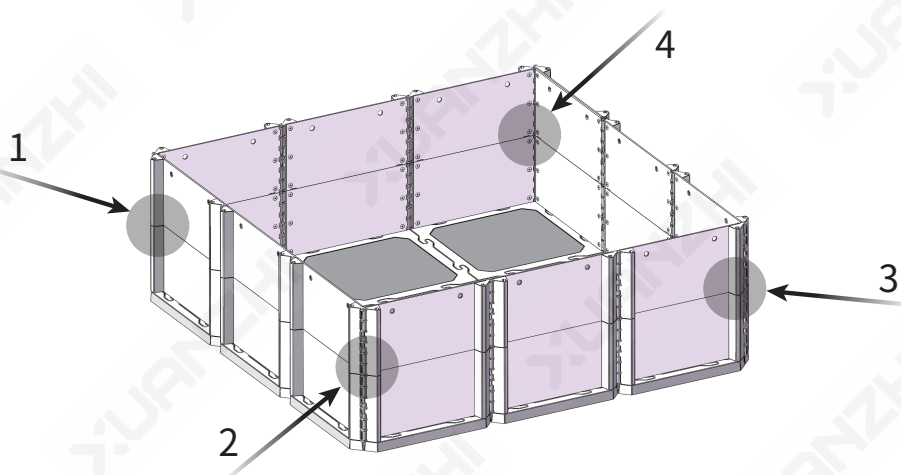

⑭ 请优先松动四角的连接处,再撬其他区域

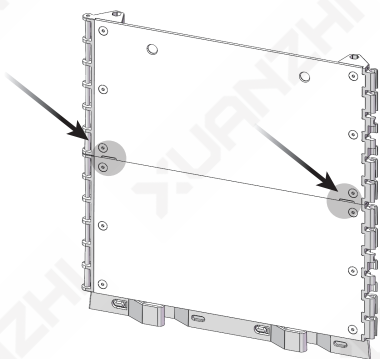

⑮ 用一字螺丝刀插入卡口处

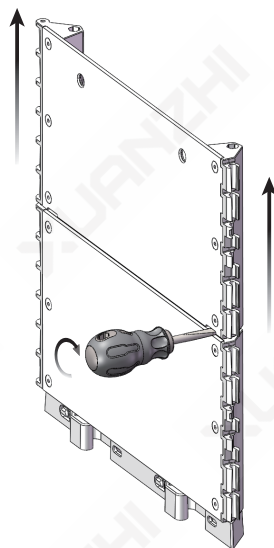

⑯ 转动螺丝刀,使连接处变松